



SPECIFICATION FOR APPROVAL

CUSTOMER:

MODEL NO: UD1238A1PBL

DESCRIPTION:

DATE: 25-Dec-08

CUSTOMER APPROVAL SIGNATURE

CUSTOMER APPROVED STAMP

*PLEASE RETURN ONE TO US AFTER CHECKING

UTECH

United thermal Engineering Corporation

1590 Oakland Road, Suite B109

San Jose, CA 95131

Tel : 408-453-1001

Fax : 408-453-1006

E-Mail : info@utecusa.com

Website: www.utecusa.com

SPECIFICATION

MULTI-FLOW	TYPE	AC AXIAL FAN	MODEL NO.	UD1238A1PBL	PAGE 1
1. MECHANICAL					
1-1 EXTERNAL DIMENSION			REFER TO DRAWING 120X120X38		
1-2 WEIGHT			500G		
1-3 PACKAGING / CUBITFEET			40pcs/Carton		
1-4 BEARING			BALL		
2. IN FRE AIR AT RATED VOLTAGE					
2-1 RETED VOLTAGE (V)			115V 60HZ		
2-2 RATED CURRENT (A)			0.25A \square \pm 10% \square		
2-3 RATED INPUT POWER (W)			20W (\pm 10%)		
3. EFFICIENCY					
3-1 RATED SPEED RANGE (R.P.M)			2800RPM \square \pm 10% \square		
3-2 MAX AIR FLOW			108CFM (AT ZERO STATICPRESSURE)		
3-3 MAX STATIC PRESSURE			0.36 Inch-H ₂ O \square AT ZERO AIR FLOW \square		
4. CHARACTERISTIC					
4-1 OPERATENG VOLTAGE RANGE (V)			110/120VAC		
4-2 STARTING VOLTAGE			\leq 60VAC		
4-3 LOCKED CURRENT			0.31A(\pm 10%)		
4-4 OPERATING TEMPERATURE			-20°C~+80°C/80%RH		
4-5 STORAGE TEMPERATURE			-20°C~+80°C/80%RH		
4-6 ENVIRONMENT HUMIDITY			10% RH 45°C FOR 24hrs&98%(RH)45°C FOR 24hrs		
4-7 TEMPERATURE RISE IN NORMAL OPERATION			TEMP. RISES LESS THAN 25°C ON SURFACE		
			TEMP. RISES LESS THAN 55°C COIL		

SPECIFICATION

MULTI-FLOW	TYPE	AC AXIAL FAN	MODEL NO.	UD1238A1PBL	PAGE 2
4-8 INSULATION RESISTANCE			100M OHMS AT 500VDC BETWEEN HOUSING AND BOTH TERMINAL PINS(Lead Wire type use Lead wire)		
4-9 DIELECTRIC STRENGTH			2000V 1mA WITH STAND 2000VAC 1 MINUTE 1Ma BETWEEN HOUSING AND BOTH TERMINAL PINS(Lead wire type use Lead wire)		
4-10 VIBRATION TEST 1			OK		
4-11 SHOCK TEST 2			OK		
4-12 TENSIBLE STRENGTH OF LEAD WIRE(Lead wire type only)			NOT BROKEN AT 1Kg FOR 15secPER PIECE		
4-13 SOUND LEVEL			□50DBA		

SPECIFICATION

MULTI-FLOW	TYPE	AC AXIAL FAN	MODEL NO.	UD1238A1PBL	PAGE 3
4-13.1 SOUND LEVEL TEST DESCRIPTION					
17					
<p>AT RAED VOLTAGE IN SOUND PROOF ROOM BACKGROUND NOISE □ 17.0 dBA MAXIMUM</p>					
4-14 CHARACTERISTIC DEFINITION					
4-14.1 RATED CURRENT RATED SPEED AND RATED INPUT POWER SHALL REACH BOTTOM LINE OF SPEC AFTER 5 MINUTES CONTINUOUS ROTATION AT RATED VOLTAGE AND REACH STANDARD SPEC AFTER 10 MINUTES CONTINUOUS ROTATION AT RATED VOLTAGE					
4-14.2 START VOLTAGE IS THE TEST VOLTAGE THAT ENABLE TO START THE FAX BY SUDDENT POWER ON					
5. PROTECTION					
LOCK TEST LOCKED 200 UNITS FOR AT LEAST 72 HOURS.FANS WORK NORMALLY AFTER LOCK RELEASED					
6. SAFETY		UL	CE	CCC	TUV
		√	√		√
7. MATERIAL					
ITEM	MAJOR COMPONENTS	MATERIAL&SPEC	GRADE	REMARK	
7-1	FAN HOUSING	Aluminiferous	A		
7-2	FAN BLADE	PBT85%+FIBER15% (D202G15)	94V-0	7BLADES	
7-3	STATOR CORE	STAINLESS STEEL SUS420J2	A		
7-4	BEARING	No.830	NSK		
7-5	SILICON STEEL STRIP	H23	A		

SPECIFICATION

MULTI-FLOW	TYPE	AC AXIAL FAN	MODEL NO.	UD1238A1PBL	PAGE 4
	MAJOR COMPONENTS		MATERIAL & SPEC	GRADE	
7.6	ENAMELED COPPER WIRES		FULL DLAMETER	PEW	
7.7	LEAD WIRE		PBL	94V-0	
7.8	LABEL		POLYESTER		
8. DESCRIPTION OF TEST					
8-1 VIBRATION TEST 1					
8-1.1 LDS 824MK VIBRATION					
TEST EQUIPMENT LDS 824MK VIBRATION TEST SYSTEM					
8-1.2 TEST ENVIRONMENT TEMPERATURE 19 HUMIDITY 67% RH					
8-1.3 5-55HzIOCT/MIN 0.75mm□P-P					
8-1.4 TEST TIME AXIS DIRECTION X Y Z THREE AXISES TAKE 16 ROTATING VIBRATION SCAN FOR EACH AXIS					
8-1.5 TEST RESULT□VIDUAL INSPECTION AND OPERATION NORMAL					

SPECIFICATION

MULTI-FLOW	TYPE	AC AXIAL FAN	MODEL NO.	UD1238A1PBL	PAGE 5
9. PRODUCT INSPECTION PROCEDURE					
INSPECTION PROCEDURES BELOW ARE EXTREMELY FOLLOWED					
9-1 100% ELECTRIC ROTATING DEAD BLADE FASTEN AND PRIMARY NOISE TEST ON					
9-2 100% TEST: 1.06 AGAIN PRESSURE 3 HOUR GO TEST					
9-3 100% TRIKE TEST BY HAND AND NOISE FILTER IN QUIET ROOM					
9-4 RANDOM INSPECTION IN ACCORDANCE WITH MIL-STD-105D STANDARD					
9-5 PASS/REJECT STANDARD					
CRITICAL AQL 0.1% MAJOR AQL 0.25% MINOR AQL 1.0%					

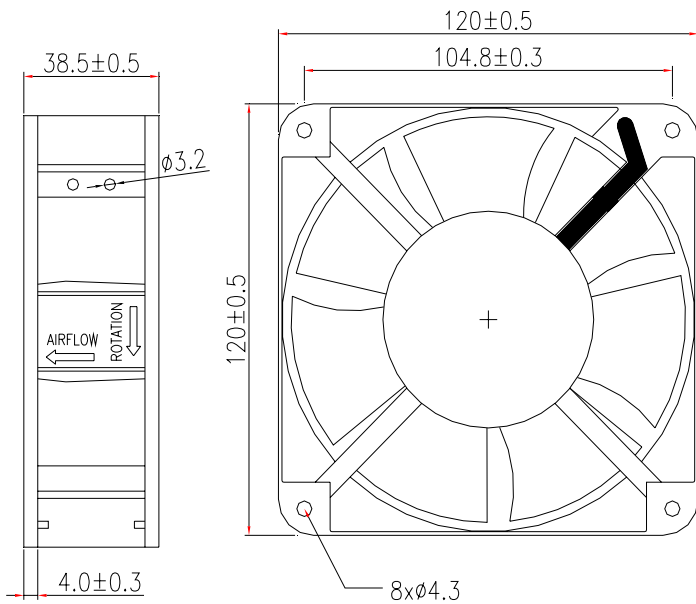

1238 CFM In ch-H2O

