



# SPECIFICATION FOR APPROVAL

CUSTOMER:

MODEL NO:

**ATB7530L-12H2B-PD1**

DESCRIPTION:

DATE:

**2008.11.07**

CUSTOMER APPROVAL SIGNATURE

|                         |
|-------------------------|
| CUSTOMER APPROVED STAMP |
|                         |

\*PLEASE RETURN ONE TO US AFTER CHECKING

**UTECH**

**United Thermal Engineering Corporation**

453 Ravendale Dr., Suite C

Mountain View, CA 94043

Tel : 650-428-1188

Fax : 650-428-1110

[E-Mail : info@utecusa.com](mailto:info@utecusa.com)

[Web Site : www.utecusa.com](http://www.utecusa.com)

# PRODUCT SPECIFICATION

## A.GENERAL SPECIFICATION

| ITEM |                         | SPECIFICATION/CONDITION  |
|------|-------------------------|--------------------------|
| A-1  | Part No.                | ATB7530L-12H2B-PD1       |
| A-2  | Outline Dimension       | B75x75x30                |
| A-3  | Rated Voltage           | 12V                      |
| A-4  | Operating Voltage Range | 6~13.8V                  |
| A-5  | Starting voltage        | 6V                       |
| A-6  | Rated Current           | 0.23A(Max:0.276A)        |
| A-7  | Power Consumption       | 3.6W                     |
| A-8  | Rated Speed             | 3000RPM±10%              |
| A-9  | Max. Airflow            | 10.58 CFM                |
| A-10 | Max Static Pressure     | 12.94 mmH2O              |
| A-11 | Noise Level             | 38.1dBA(Max:40.7dBA)     |
| A-12 | Rotation Direction      | Anti-clockwise Direction |
| A-13 | ATB7530L-12H2B-PD1      | AutoRestart Function     |

## B.ELECTRICAL SPECIFICATION

| ITEM |                             | SPECIFICATION/CONDITION  |
|------|-----------------------------|--|
| B-1  | Temperature life expectancy | 70000 Hours(45°C)  |
| B-2  | Insulation Resistance       | At least 10MΩ at 500VDC between housing and both lead wires.       |
| B-3  | Dielectric Strength         | Withstand 600VAC 1 minute 1Ma between housing and both lead wires. |

## C.MAIN MATERIAL/PARTS SPECIFICATION

| ITEM | MAJOR COMPONENTS   | MATERIAL OR TYPE      | GRADE |
|------|--------------------|-----------------------|-------|
| C-1  | Housing & Impeller | Plastic               |       |
| C-2  | Splash Proof       | NO                    |       |
| C-3  | Weight             | 86g                   |       |
| C-4  | LEAD WIRES         | UL1007#26 Single Wire |       |
| C-5  | CONNECTOR HOUSING  | NP Two lead wire      |       |
| C-6  | CONNECTOR          |                       |       |
| C-7  | BEARING            | Ball Bearing          |       |

## D.ENVIRONMENTAL SPECIFICATION

| ITEM |                       | SPECIFICATION/CONDITION |
|------|-----------------------|-------------------------|
| D-1  | Operation Temperature | -10°C,~+70°C, /66%(RH)  |
| D-2  | Storage Temperature   | -40°C,~+70°C, /66%(RH)  |
| D-3  | Environment Humidity  | Less than 85%(RH)       |

## E-1.Shock test

Pulse shape : Half-sine wave

Shock duration time : 2ms

Velocity : 70~100 inch/sec

Number of shock : one shock for each of six faces ( Total : six shocks )

## E-2.Vibration

Frequency range : 10~500Hz scan 15 minutes .

Direction : X、 Y、 Z .

Acceleration : 1.5g r.m.s , each direction 2 hours .

Figure 1. Fan Performance Curve

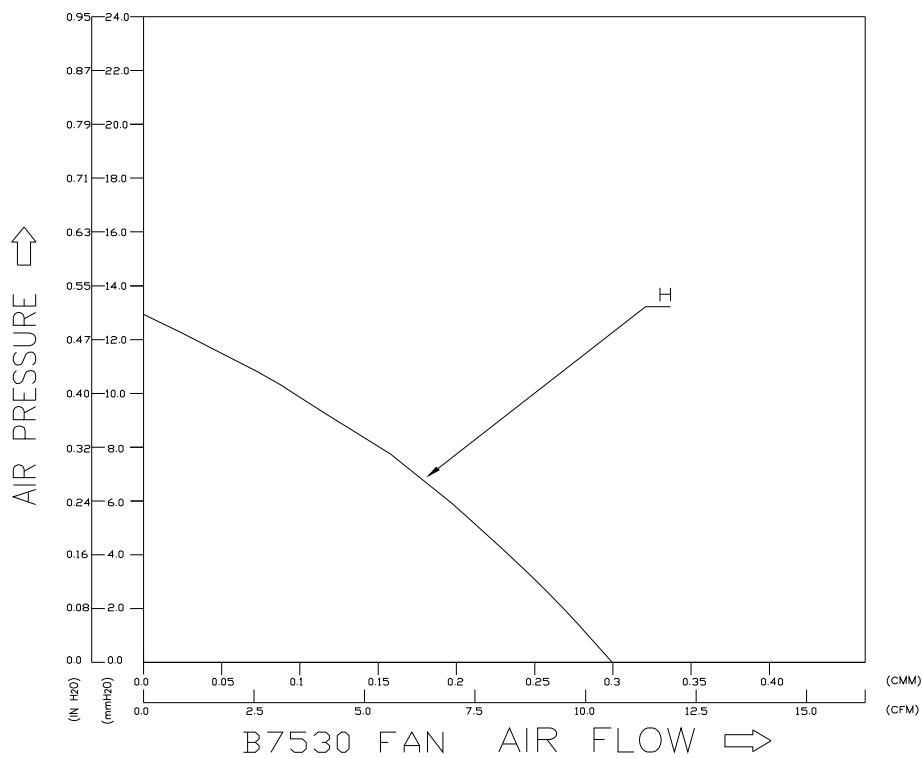
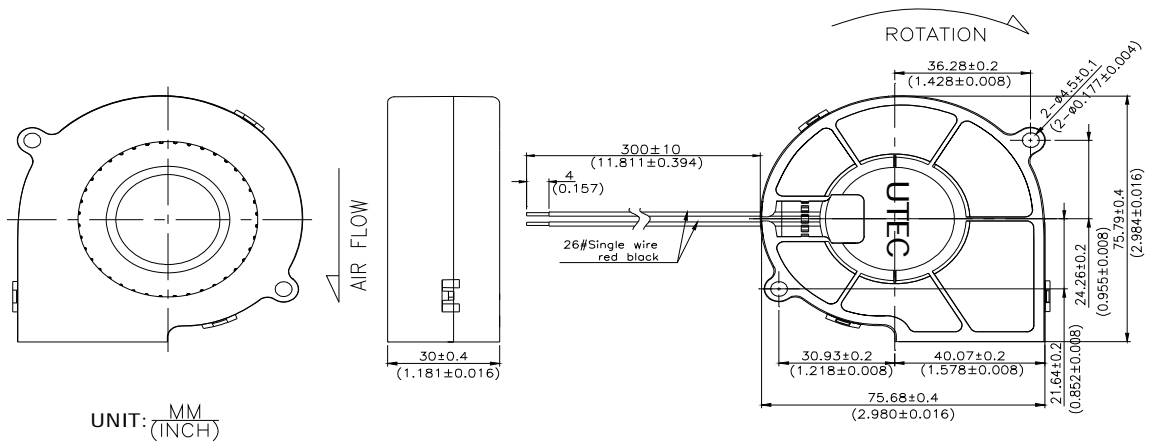

Figure 2 Fan Dimension & Assembly



Notes:

1. Tolerances:
2. Impeller must not protrude beyond front surface
3. Minimum 0.50 radius at all rib intersections
4. Unit: mm