



# SPECIFICATION FOR APPROVAL

CUSTOMER:

MODEL NO:

**ATB6025L-12H2B-PD1**

DESCRIPTION:

DATE:

**2008.12.05**

CUSTOMER APPROVAL SIGNATURE

CUSTOMER APPROVED STAMP

\*PLEASE RETURN ONE TO US AFTER CHECKING

**UTECH**

**United Thermal Engineering Corporation**

453 Ravendale Dr., Suite C

Mountain View, CA 94043

Tel : 650-428-1188

Fax : 650-428-1110

[E-Mail : info@utecusa.com](mailto:info@utecusa.com)

[Web Site : www.utecusa.com](http://www.utecusa.com)

# PRODUCT SPECIFICATION

## A.GENERAL SPECIFICATION

ITEM		SPECIFICATION/CONDITION	
A-1	Part No.	ATB6025L-12H2B-PD1	
A-2	Outline Dimension	B60x60x25	
A-3	Rated Voltage	12V	
A-4	Operating Voltage Range	6~13.8V	
A-5	Starting voltage	6V	
A-6	Rated Current	0.4A (Max:0.46A)	
A-7	Power Consumption	4.8W(Max:5.52W)	
A-8	Rated Speed	4500RPM±10%	
A-9	Max. Airflow	10.55 CFM	
A-10	Max Static Pressure	28.1 mmH <sub>2</sub> O	
A-11	Noise Level	43.3 dBA (Max:45.4dBA)	
A-12	Rotation Direction	Anti-clockwise Direction	
A-13	ATB6025L-12H2B-PD1	Auto Restart Function	

## B.ELECTRICAL SPECIFICATION

ITEM		SPECIFICATION/CONDITION	
B-1	Temperature life expectancy	70000 Hours(45°C)	
B-2	Insulation Resistance	At least 10MΩ at 500VDC between housing and both lead wires.	
B-3	Dielectric Strength	Withstand 600VAC 1 minute TMA between housing and both lead wires.	

## C.MAIN MATERIAL/PARTS SPECIFICATION

ITEM	MAJOR COMPONENTS	MATERIAL OR TYPE	GRADE
C-1	Housing & Impeller	Plastic	
C-2	Splash Proof	NO	
C-3	Weight	50.4g	
C-4	LEAD WIRES	UL1007#26 Single Wire	
C-5	CONNECTOR HOUSING	NP Two lead wire	
C-6	CONNECTOR		
C-7	BEARING	Ball Bearing	

## D.ENVIRONMENTAL SPECIFICATION

ITEM		SPECIFICATION/CONDITION	
D-1	Operation Temperature	-10°C,~+70°C, /66%(RH)	
D-2	Storage Temperature	-40°C,~+70°C, /66%(RH)	
D-3	Environment Humidity	Less than 85%(RH)	

## E-1.Shock test

Pulse shape : Half-sine wave

Shock duration time : 2ms

Velocity : 70~100 inch/sec

Number of shock : one shock for each of six faces ( Total : six shocks )

## E-2.Vibration

Frequency range : 10~500Hz scan 15 minutes .

Direction : X、 Y、 Z .

Acceleration : 1.5g r.m.s , each direction 2 hours .

Figure 1. Fan Performance Curve

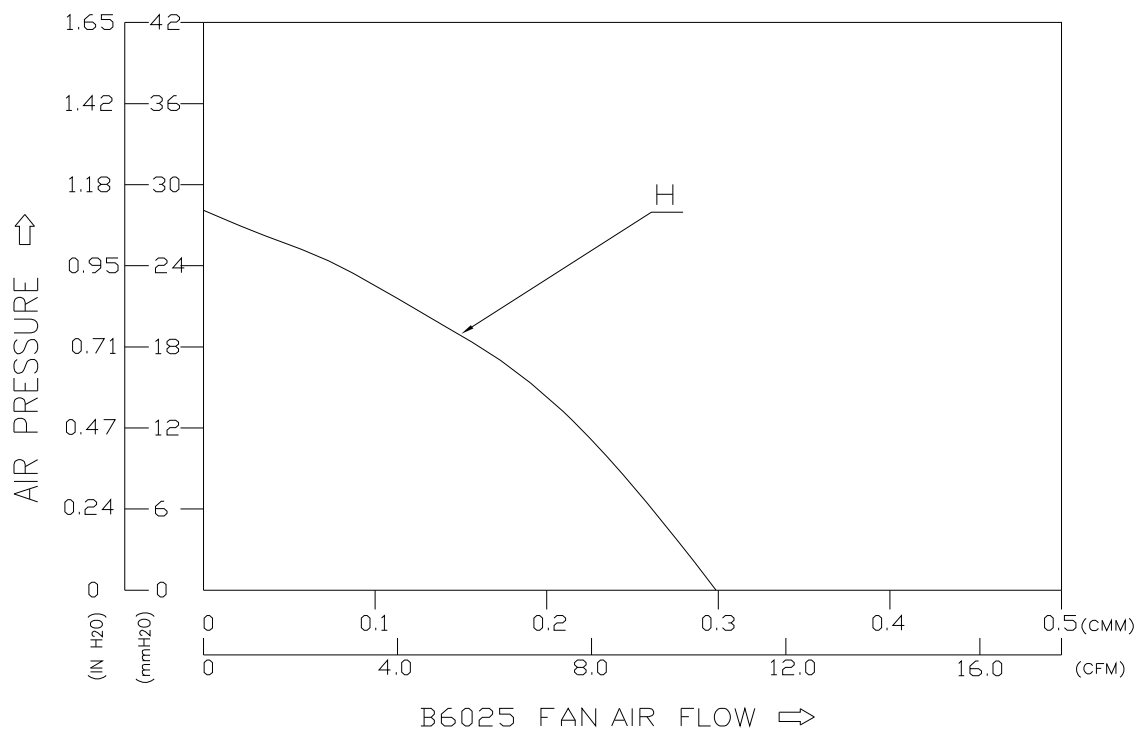

## Figure 2 Fan Dimension & Assembly

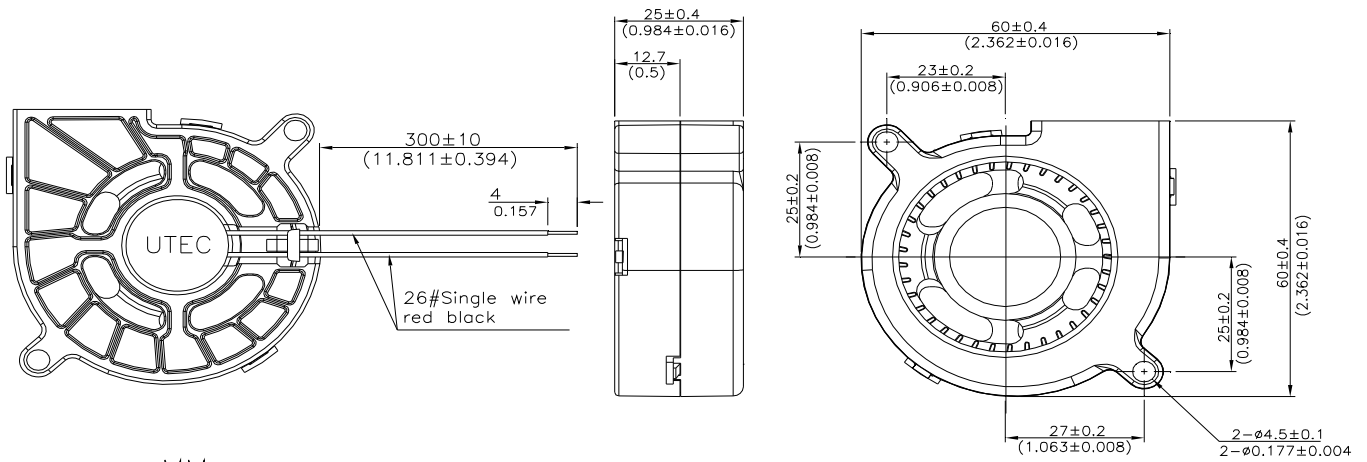

UNIT:  $\frac{\text{MM}}{\text{INCH}}$

### Notes:

1. Tolerances:
2. Impeller must not protrude beyond front surface
3. Minimum 0.50 radius at all rib intersections
4. Unit: mm