



SPECIFICATION FOR APPROVAL

CUSTOMER:

MODEL NO:

AT1238L-48M2B-PD1

DESCRIPTION:

DATE:

2009.4.13

CUSTOMER APPROVAL SIGNATURE

| |
|-------------------------|
| CUSTOMER APPROVED STAMP |
| |

*PLEASE RETURN ONE TO US AFTER CHECKING

UTECH

United Thermal Engineering Corporation

1590 Oakland Rd. Suite B109

San Jose, CA 95131

Tel : 408-453-1001

Fax : 408-453-1006

E-Mail : info@utecusa.com

Web Site : www.utecusa.com

PRODUCT SPECIFICATION

A.GENERAL SPECIFICATION

| ITEM | | SPECIFICATION/CONDITION |
|------|-------------------------|--------------------------|
| A-1 | Part No. | AT1238L-48M2B-PD1 |
| A-2 | Outline Dimension | 12x12x38 |
| A-3 | Rated Voltage | 48V |
| A-4 | Operating Voltage Range | 24~52.8V |
| A-5 | Starting voltage | 24V |
| A-6 | Rated Current | 0.18A(Max:0.216A) |
| A-7 | Power Consumption | 2.16W(Max:14.4W) |
| A-8 | Rated Speed | 2400RPM±10% |
| A-9 | Max. Airflow | 119.68 CFM |
| A-10 | Max Static Pressure | 4.97 mmH ₂ O |
| A-11 | Noise Level | 42.6 dBA(Max:45.5dBA) |
| A-12 | Rotation Direction | Anti-clockwise Direction |
| A-13 | AT1238L-48M2B-PD1 | Auto Restart Function |

B.ELECTRICAL SPECIFICATION

| ITEM | | SPECIFICATION/CONDITION |
|------|-----------------------------|--|
| B-1 | Temperature life expectancy | 70000 Hours (45°C) |
| B-2 | Insulation Resistance | At least 10MΩ at 500VDC between housing and both lead wires. |
| B-3 | Dielectric Strength | Withstand 600VAC 1 minute 1Ma between housing and both lead wires. |

C.MAIN MATERIAL/PARTS SPECIFICATION

| ITEM | MAJOR COMPONENTS | MATERIAL OR TYPE | GRADE |
|------|--------------------|-----------------------|-------|
| C-1 | Housing & Impeller | Plastic | |
| C-2 | Splash Proof | NO | |
| C-3 | Weight | 215.6g | |
| C-4 | LEAD WIRES | UL1007#24 Single Wire | |
| C-5 | CONNECTOR HOUSING | NP Two lead wire | |
| C-6 | CONNECTOR | | |
| C-7 | BEARING | Ball Bearing | |

D.ENVIRONMENTAL SPECIFICATION

| ITEM | | SPECIFICATION/CONDITION |
|------|-----------------------|-------------------------|
| D-1 | Operation Temperature | -10°C,~+70°C, /66%(RH) |
| D-2 | Storage Temperature | -40°C,~+70°C, /66%(RH) |
| D-3 | Environment Humidity | Less than 85%(RH) |

E-1.Shock test

Pulse shape : Half-sine wave

Shock duration time : 2ms

Velocity : 70~100 inch/sec

Number of shock : one shock for each of six faces (Total : six shocks)

E-2.Vibration

Frequency range : 10~500Hz scan 15 minutes .

Direction : X 、 Y 、 Z .

Acceleration : 1.5g r.m.s, each direction 2 hours .

Figure 1. Fan Performance Curve

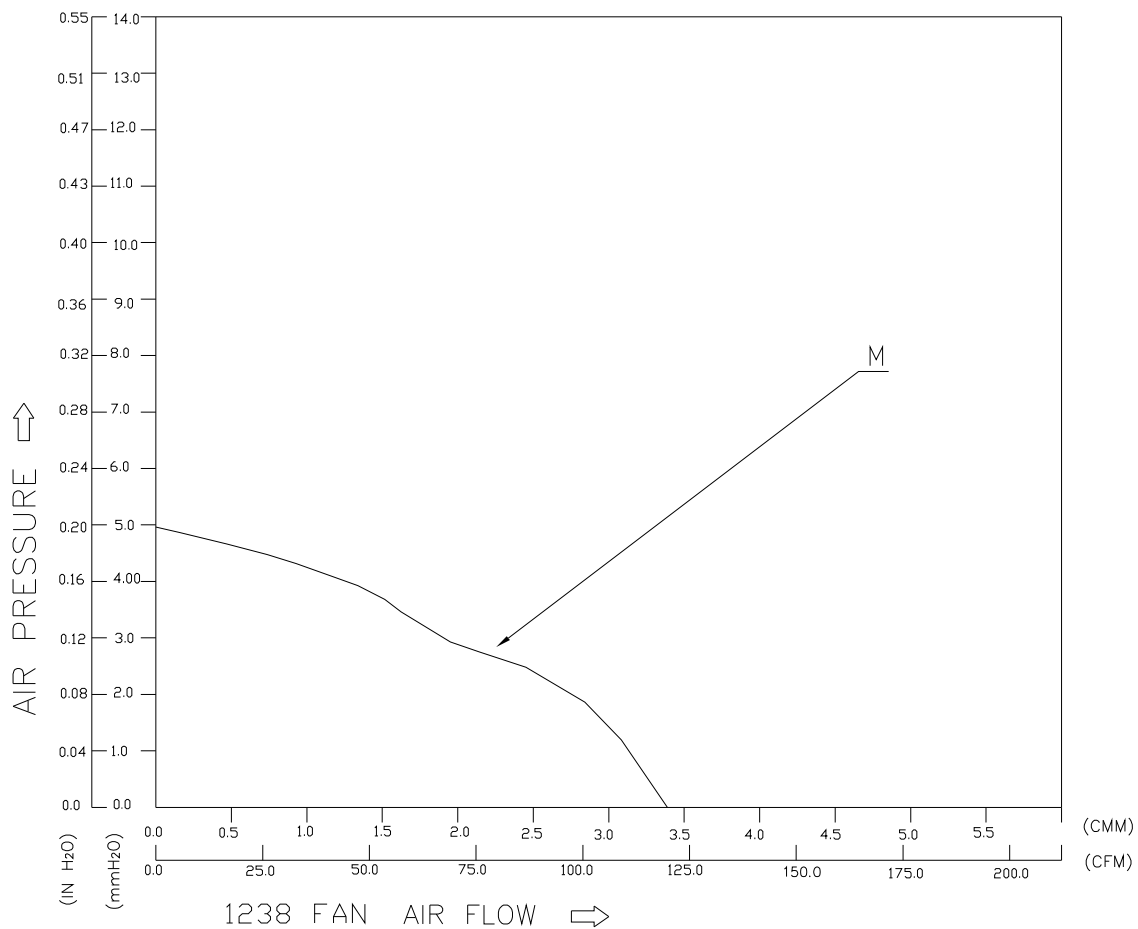
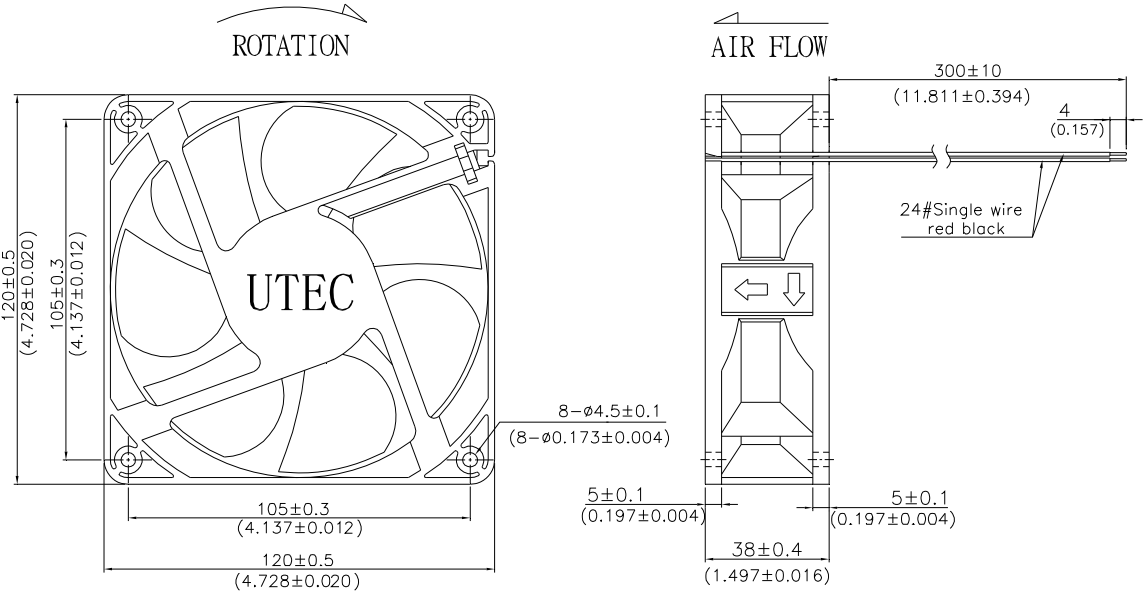

Figure 2 Fan Dimension & Assembly



UNIT: $\frac{MM}{(INCH)}$

- Notes:
1. Tolerances:
 2. Impeller must not protrude beyond front surface
 3. Minimum 0.50 radius at all rib intersections
 4. Unit: mm